

DuraLedge HD - 400 LBS Max Installation Instructions

What's included:

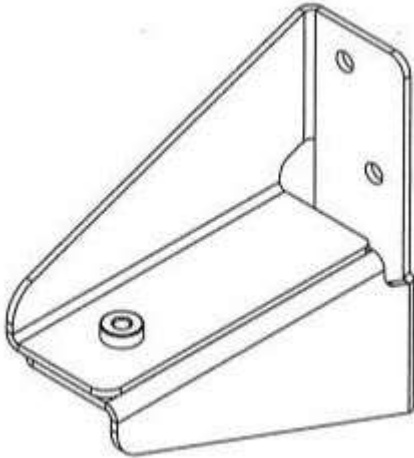

Bracket-qty 4



4" Leg Leveler-qty 4



1 1/4" x 1/4" Washer-qty 12



2 1/2" x 1/4" Machine Screw-qty 12



1/4" Split Lockwasher-qty 12



1/4" Hex Nut-qty 12



5/8" Pan Head Screw-qty 4



6.3mm x 10mm Screw-qty 4

(these screws are for cabinet shop CNC Install)



3/8" Hex Nut- Qty 4

Tools Needed:

Sink Manufacturers Specifications

Safety Glasses

Power Drill

5/16" Wood Drill Bit

#2 Phillips Bit

7/16" Socket or Adjustable Wrench

1/4" Socket or Flat Head Screwdriver (adjust leg leveler)

Masking Tape For Marking (optional)

Tape Measure

Level

Pencil

Read These Tips

Doing so will ensure a great product

Manufacture will not be held responsible for damage to any product or other products due to incorrect installation, or negligence.

- **Add 3/8" hex nut to leg leveler prior installation and tighten the hex nut against the weld nut after the sink is set. Hex nut goes above the weld nut.**
- **Finished sink weight not to exceed 400 lbs.**
- **Weld nuts for adjustable posts must be positioned to the top side of the bracket for proper installation.**
- **Lower sink down by 1/8" after countertops have been measured, then raise to final position after countertops are installed.**
- **Do not over tighten leg levelers when raising the sink against the bottom of the countertop.**
- **If the sink cabinet has cabinets to be attached to either side, fasten cabinets together prior to the start of installation.**
- **Any obstructions in flanking cabinets or appliances must be removed prior drilling. Such as shelving, pull outs, trash pullouts/bins, dishwashers, etc.**
- **Cabinetry with less than 1/2" side walls may need reinforcement.**
- **Any Voids between cabinets must be filled prior to installation of bracket bolts going through both walls. Illustration below shows typical voids.**
- **Brackets must be mounted vertically straight.**
- **Install leg levelers after brackets have been installed and secured.**
- **Brackets recommended to be installed a minimum of 3 1/2" away from drain(s).**
- **Split lock washer and hex nut installed against bracket, Inside Cabinet.**
- **Video available online.**



Installation

Referencing sink manufactures specifications, note the sink height (top to bottom) and depth (front to back) needed for your specific application.

Height needed for sink, Plus (+) 3 1/4" is 3rd hole down from the top of the bracket. Bracket weld nut for adjustable post faces up.

The bracket locations from front of cabinet to back of cabinet will be determined by your specific sink.

Fasten brackets using the 5/8" Pan head screw into the 3rd hole down from the top of the bracket.



Level bracket vertically.

Mark Holes 1,2,&4.

If needed remove bracket and drill holes 1, 2, & 4 with 5/16" drill bit.

Reinstall bracket using 5/8" Pan Head Screws.

Finish installing brackets using hardware provided. Large washer to exterior of cabinet.

Lock washer then nut for interior of cabinet.

Install leg leveler with 3/8" hex nut above the weld nut, insert sink and adjust for fit as needed.

Once the sink is in its final position, move 3/8" hex nut down to sit snug against the weld nut.